

SH Type

SHORT HEAD TYPE HOIST

로우 헤드룸형 호이스트

후크를 레일의 하면근처 최대높이까지 권상시킬 수 있어 설치된 구조물 및 최단거리가 제한된 현장에서의 사용에 적합합니다. 건축 설계시 SH Type의 적용을 기본으로 설계 할 경우 건축물의 높이를 보다 더 낮출 수 있어 경비절감효과를 볼 수 있습니다.

SH Type hoist has unique design construction with reduced headroom. It's specifically designed to be used in buildings with low ceiling, especially in provisionally constructed building or those in which extended effective lifting height is required.

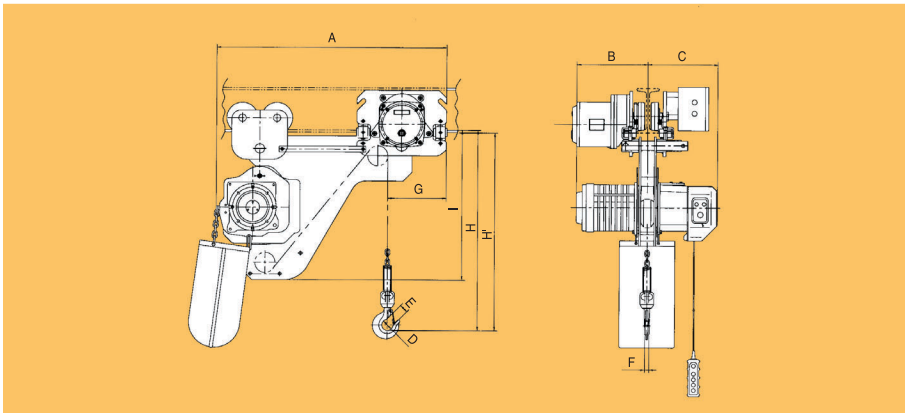

Model		SH-1S		SH-1.5S		SH-2S		SH-2W		SH-2.5S		SH-2.8W		SH-3W		SH-5W	
		DA	DB	DA	DB	DA	DB	DA	DB	DA	DB	DA	DB	DA	DB	DA	DB
Standard Load(TON)		1		1.5		2		2		2.5		2.8		3		5	
Lifting Speed (m/min)	50Hz	6.8	6.8/2.2	8.7	8.7/2.9	6.9	6.9/2.3	3.4	3.4/1.1	5.5	5.5/1.8	4.35	4.35/1.4	4.35	4.35/1.4	2.75	2.75/0.9
	60Hz	8.2	8.2/2.7	10.3	10.3/3.4	8.1	8.1/2.7	4.1	4.1/1.3	6.5	6.5/2.1	5.15	5.15/1.7	5.15	5.15/1.7	3.25	3.25/1.0
Dimension (mm)	A	825	825	866.5	866.5	866.5	866.5	812.5	812.5	889	889	889	889	889	889	914	914
	B	308	338	358	383	358	383	308	338	358	383	358	383	358	383	358	383
	C	274	298	313	345	313	345	274	298	313	345	313	345	313	345	313	345
	D	φ 35	φ 35	φ 53.5	φ 53.5	φ 53.5	φ 53.5	φ 53.5	φ 53.5	φ 60	φ 60	φ 60	φ 60	φ 60	φ 60	φ 70	φ 70
	E	25	25	40	40	40	40	40	40	44	44	44	44	44	44	58	58
	F	24	24	30	30	30	30	30	30	37	37	37	37	37	37	46	46
	G	255	255	262.5	262.5	262.5	262.5	217.5	217.5	253	253	256.5	256.5	256.5	256.5	290	290
	H(min)	441	441	483.5	483.5	483.5	483.5	490	490	496	496	617	617	564	564	564	564
	H'	507	507	556	556	556	556	546	546	558	558	558	558	630	630	653	653