

## DOUBLE RAIL CHAIN HOIST

### 더블 레일 체인 호이스트

기존 와이어 이중레일 호이스트와 호환이 가능하도록 모노레일 체인 호이스트를 기본으로 한 이중레일 체인 호이스트를 개발하여 안전성이 높고 작업이 용이하도록 복합적인 기능을 제공합니다.

New complex concept double rail hoist which is base on monorail chain hoist has compatibility with double rail wire hoist.

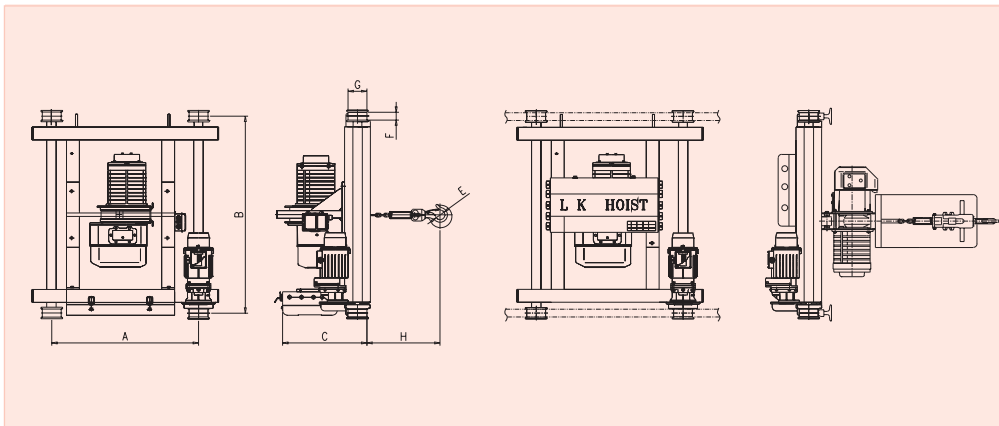
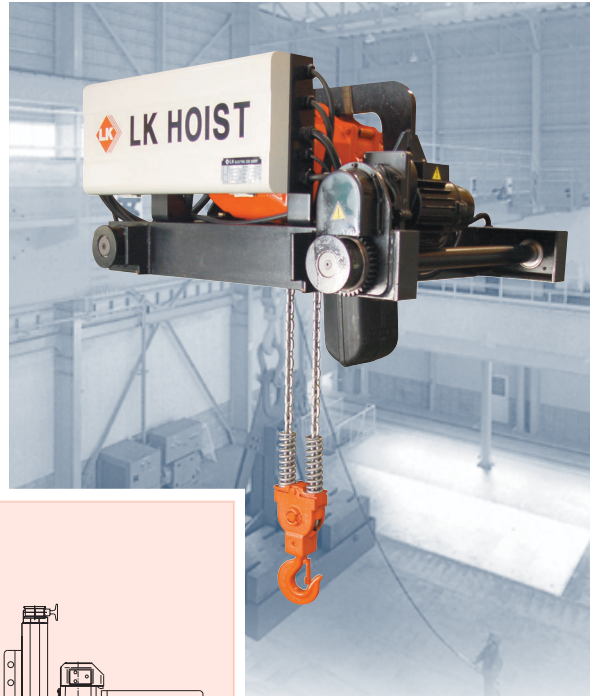

Model		0.5	DAD-1S	DAD-2W	DAD-1.5S	DAD-2S	DAD-2.5S	DAD-2.8W	DAD-3W	DAD-5W
Standard Load(TON)			1	2	1.5	2	2.5	2.8	3	5
Standard Lift(m)		4	4	4	4	4	4	4	4	4
Dimension (mm)	A	853	853	853	853	853	853	853	853	858
	B	950	950	950	950	950	950	950	950	1150
	C	560	560	560	560	560	560	560	560	560
	H	45	45	227	115	132	146	318	318	365
	E	φ 35	φ 35	φ 53.5	φ 53.5	φ 53.5	φ 60	φ 60	φ 60	φ 70
	F	47	47	47	47	47	47	47	47	47
	G	φ 110	φ 110	φ 110	φ 110	φ 110	φ 110	φ 110	φ 110	φ 110
Chain Size(mm)		φ 7.1×21	φ 7.1×21	φ 7.1×21	φ 9.5×28.6	φ 11.2×34	φ 11.2×34	φ 9.5×28.6	φ 9.5×28.6	φ 11.2×34
Lifting Speed (m/min)	50Hz	6.8	6.8	3.4	8.7	6.9	5.5	4.35	4.35	2.75
	60Hz	8.2	8.2	4.1	10.3	8.1	6.5	5.15	5.15	3.25
Traversing Speed (m/min)	4P	17.2	17.2	17.2	24	24	24	17.2	24	17.2
	6P	12.7	11.7	11.7	16	16	16	11.7	16	11.7
Net Weight(kg)			210	246	307	333	363	373	373	468